



SPP

*Southwest
Power Pool*

***Facility Study
For
Generation Interconnection
Request
GEN-2011-045***

***SPP Generation
Interconnection***

(#GEN-2011-045)

July 2012

Summary

Xcel Energy Inc (Xcel), a subsidiary of Southwestern Public Service Company (SPS), performed a detailed Facility Study at the request of Southwest Power Pool (SPP) for Generation Interconnection request GEN-2011-045 (180 MW in Summer, 205 MW in Winter/ Combustion Turbine). The originally proposed in-service date was June 1, 2013. The request for interconnection was placed with SPP in accordance with SPP's Open Access Transmission Tariff, which covers new generation interconnections on SPP's transmission system. Subsequent to the Definitive Interconnection System Impact Study (DISIS-2011-002) study, a request for a Limited Operation Interconnection Service (LOIS) study was performed by SPP and posted May 2012. Through the LOIS analysis, power system stabilizers (PSS) are needed.

Phases of Interconnection Service

It is not expected that interconnection service will require phases however; the LOIS analysis shows that the full amount of the request can be interconnected on a Limited Operation basis beginning on March 1, 2013 if the power system stabilizers (PSS) are installed.

Interconnection Customer Interconnection Facilities

The Interconnection Customer will be responsible for all of the transmission facilities connecting the customer owned substation to the Point of Interconnection (POI) an existing generator lead at SPS Jones 230kV. Additionally, Interconnection Customer will have to install a new terminal at the existing Point of Interconnection (POI) and allow for relay coordination with the interconnection substation, SPS Jones 230kV. Finally, the Customer will also be responsible for any equipment located at the Customer substation necessary to maintain a power factor of 0.95 lagging to 0.95 leading at the POI.

Transmission Owner Interconnection Facilities and Non-Shared Network Upgrades

To allow interconnection the Transmission Owner will need to ensure that relay settings at Jones 230kV are adequate for the additional injection of GEN-2011-045. The estimated in-service date for these Interconnection Facilities is unknown but the newly proposed in-service date will be after the Power System Stabilizers (PSS) and Network Upgrades are completed. At this time the Customer is responsible for \$2,187,010 of Transmission Owner Interconnection Facilities and Non-Shared Network Upgrades.

Shared Network Upgrades

The interconnection customer was studied within the DIS-2011-002 Impact Study. At this time, the Interconnection Customer is allocated \$8,993,473 for Shared Network Upgrades, as listed below:

1. Power System Stabilizers (PSS) at Tolk (Units: 1,2) and Jones (Units: 1,2,3,4)
2. Allen – Lubbock South 115kV circuit 1, rebuild (NRIS Only)
3. Jones – Lubbock South 230kV, replace line traps, (NRIS Only)
4. Jones – Tucco 230kV circuit 1, replace line traps (NRIS Only)
5. Lubbock South – Lubbock East 115kV circuit 1, rebuild, (NRIS Only)
6. Lubbock South 230/115kV Autotransformer circuit 2, build, (NRIS Only)

If higher queued interconnection customers withdraw from the queue, suspend or terminate their GIA, restudies will have to be conducted to determine the Interconnection Customers' allocation of

shared network upgrades. All studies have been conducted on the basis of higher queued interconnection requests and the upgrades associated with those higher queued interconnection requests being placed in service.

Other Network Upgrades

Certain Other Network Upgrades are currently not the cost responsibility of the Customer but will be required for full Interconnection Service. These Network Upgrades include:

1. Beaver – Woodward 345kV double circuit, scheduled for 6/30/2014 in-service
2. Beaver County – Gray County (Buckner) 345kV, assigned to DIS-2011-001 Customers
3. Beaver County 345kV Expansion, assigned to DIS-2010-002 Customers
4. Woodward – Border - TUCO 345kV, scheduled for 5/19/2014 in-service
5. Hitchland – Beaver County - Woodward 345kV double circuit, scheduled for 6/30/2014 in-service
6. Hitchland 345/230 transformer circuit 2, scheduled for 6/30/2014 in-service
7. Thistle - Woodward 345kV double circuit, scheduled for 12/31/2014 in-service
8. Thistle – Wichita 345kV double circuit, scheduled for 12/31/2014 in-service
9. Thistle 345/138kV Transformer circuit 1, scheduled for 12/31/2014 in-service
10. Woodward 345/138kV Transformer circuit 2, scheduled for 05/14/2014 In-service

Depending upon the status of higher or equally queued customers, the Interconnection Customer's in-service date is at risk of being delayed or their Interconnection Service is at risk of being reduced until the in-service date of these Other Network Upgrades.

Conclusion

Interconnection Service for GEN-2011-045 will be delayed until the Transmission Owner Interconnection Facilities and Network Upgrades are constructed. The Customer is responsible for \$2,187,010 of Transmission Owner Interconnection Facilities and Non-Shared Network Upgrades. At this time, the Interconnection Customer is also allocated \$8,993,473 for Shared Network Upgrades. After all Interconnection Facilities and Network Upgrades have been placed into service, Interconnection Service for 205MW, as requested by GEN-2011-045, can be allowed. At this time the total allocation of costs of Interconnection Service for GEN-2011-045 are estimated at \$11,180,48.



**Facilities Study For
Southwest Power Pool (SPP)**
180 MW Generation Facilities
Lubbock County, Texas
SPP #GEN-2011-045

July 12, 2012

Xcel Energy Services, Inc.
Transmission Planning

Executive Summary

Xcel Energy's Energy Supply ("Interconnection Customer") in 2011 requested the interconnection of a new generation facility located in Lubbock County, Texas to the Southwestern Public Service Company (SPS) transmission network. SPS is a New Mexico Corporation and wholly owned subsidiary of Xcel Energy Inc. This facility has a net capacity of 180 MW in the Summer and 205 MW in the Winter. The Interconnection Customer's facility will connect to the existing SPS Jones Interchange 230 kV located approximately 4 miles southeast of Lubbock, Texas. The Interconnection Customer's expected commercial operation date is June 1, 2013 and back-feed date is February 15, 2013.

The Southwest Power Pool (SPP) evaluated the request to interconnect the generator facility to the SPS transmission system in a Definitive Interconnect System Impact Study (DISIS-2011-002) Interconnection Customer completed in January 2011. The interconnection request was studied using one (1) Siemens Gas Generator for a total output of 180 MW. The Interconnection Customer will be required to maintain a Power Factor of 0.95 lagging and 0.95 leading at the Point of Interconnection (POI).

SPS requires that all construction for this request be in compliance with the latest revision of the Xcel Energy Interconnection Guidelines for Transmission Interconnection Producer-Owned Generation Greater than 20 MW, available at:

http://www.xcelenergy.com/Texas/Company/Transmission/Pages/Transmission_Services_Interconnection_Guidelines.aspx). This document describes the requirements for connecting new generation to the Xcel Energy transmission systems including technical, protection, commissioning, operation, and maintenance. Also, this document has a section on Frequency and Frequency Control for the SPP Region on page 21, under SPP criteria, to open tie lines at 58.5 Hz and automatically trip generators. Due to the structure of the under-frequency load-shedding plan, it is necessary that generators be able to sustain frequencies to at least 58.5 Hz. SPS will also require that the Interconnection Customer be in compliance with all applicable criteria, guidelines, standards, requirements, regulations, and procedures issued by the North American Electric Reliability Corporation (NERC), Southwest Power Pool (SPP), and the Federal Energy Regulatory Commission (FERC) or their successor organizations.

The Interconnection Customer is responsible for the cost of the Interconnection Facilities, installation of the Direct Assigned Interconnection Facilities; inclusive of all construction required for the 230 kV transmission line from the Interconnection Customer's substation to the SPS Jones Interchange.

"Limited Operation Studies for the early operation of the Interconnection Customer shows a need for the installation of power system stabilizers (PSS) on the following generating units in the SPS transmission system.

- Tolk Unit #1-#2
- Jones Unit #1-#4
-

The cost to install and initialize the power system stabilizers for these units is estimated at \$50,000 each. This cost is to be shared by all interconnection customers requesting Limited Operation prior to the network upgrades in DISIS-2011-002 being placed in service". This could eliminate several projects listed below under the estimated allocation costs.

The current shared upgraded allocated to Interconnection Customer as calculated by SPP include Jones – Lubbock South line traps; Jones – TUCO 230 kV line traps; Lubbock South – Lubbock East 115 kV line reconductor; and a 2nd 230/115 kV autotransformer at Lubbock South. The allocation or makeup of these network upgrades may change as the content of the GI Cluster group changes.

As for this Interconnection Customer, it is anticipated that the entire process of adding the new 230 kV line terminals at Jones Interchange for the acceptance of the Jones Generator Unit #4 facility output, will require approximately 12 months to complete after an Interconnection Agreement is signed and an authorization to proceed is received. The cost of these upgrades, inclusive of the Interconnection Customer's cost for the interconnection of this Gas Generator facility, is shown below in Table 1, with the detailed description of the cost shown in Table 3.

Table 1, Cost Summary^a

Transmission Owner Network Upgrades:	\$ 1,957,010
Transmission Owner Interconnection Facilities:	\$ 230,000
Total:	\$ 2,187,010

^a The cost estimates are 2012 dollars with an accuracy level of ±20%.

General Description of SPS^b Facilities

1. **Construction of New Line Terminal:** See Appendix A, Figure A- 1 for general vicinity location map.
 - 1.1. **Location:** SPS will add a new 230 kV line terminal at the existing SPS Jones Interchange. Appendix A, Figure A- 2, shows a one-line of the new breaker configuration at Jones Interchange, Figure A-3 shows a typical elevation view of the Point of Interconnection (POI).
 - 1.2. **Bus Design:** The initial interconnection shall be to the existing breaker and half bus design at Jones Interchange to accommodate the outputs from the new Gas Generator facility. This is shown in Appendix A, Figure A-2.
 - 1.3. **Line Terminals:** The 230kV lines and static wire terminals will be designed to accommodate 2,000 pounds per phase conductor at maximum tension, with a maximum 15-degree pull off from normal.
 - 1.4. **Control House:** The existing control house will accommodate the new metering, protective relaying and control devices, terminal cabinets, and any fiber-optic cable terminations, etc. for the new 230 kV line breaker terminal.
 - 1.5. **Security Fence:** The existing security fence shall be extended if required when the new bay is added for the new 230 kV line terminal.
 - 1.6. **Ground Grid:** The existing ground grid shall be extended to accommodate the additional bay required for the new line terminal per ANSI/IEEE STD 80-1986, with our standard 4/0 copper ground mesh on 40-foot centers with ground rods and 20-foot centers in corners and loop outside of fence.
 - 1.7. **Site Grading:** Company contractor, per company specifications, will perform any site grading and erosion control to accommodate the new line terminal. Soil compaction shall be not less than 95% of laboratory density as determined by ASTM-D-698.
 - 1.8. **Station Power:** The existing station power, provided from the local distribution system, will be utilized.
 - 1.9. **Relay and Protection Scheme:** The new 230 kV breaker line terminal primary protection to the interconnection customer 230 kV transmission line will use line current differential relaying over optical fiber installed in the static of the customer's 230 kV transmission line. Secondary relaying will use mirrored bit, Permissive Overreaching Transfer Trip (POTT) over the optical fiber. An SEL 311L and an SEL 421-1 will be used as primary and secondary relays, respectively. The SEL 421-1 will be used for line/bus SCADA closing conditions for the 230 kV breakers. Also, a SEL 501-0 will be used for breaker failure.

An SEL 421-1 will display the bus voltage, GCB amps, MW, MVAR, and fault location. A communication relay will be installed and for other functions as required.
 - 1.10. **Revenue Metering:** On the proposed SPS Jones Interchange 230 kV line terminal to the Interconnection Customer's substation, an individual billing meter will be installed, which meets the standards: ANSI C12.1 accuracy class 0.2 (3-PT's IEEE C57.13 accuracy class 0.3

^b All modifications to SPS facilities will be owned, maintained and operated by SPS.

and 3 CT's IEEE C57.13 accuracy class 0.15) for full 3 phase 4-wire metering. Also installed for the metering units will be 3-PT's and 3-CT's for full 3-phase 4-wire metering. There will be one meter per line terminal with full 4 quadrant metering. Pulses out of the primary billing meter will be sent via SCADA to the Transmission Owner's Control Center in Amarillo, Texas.

- 1.11. **Disturbance Monitoring Device:** Disturbance-monitoring equipment (DFR), capable of recording faults, swings, and long term trending, will be installed to monitor and record conditions in the substation and on the transmission lines. The disturbance equipment shall also be equipped with a GPS time synching clock. This equipment will have communication capability with a dedicated communication circuit. The disturbance equipment will have its own dedicated dial-up communications telephone circuit.
- 1.12. **Remote Terminal Unit (RTU):** An existing RTU will be utilized to accommodate for the new 230 kV line terminal at Jones Interchange. SPS will provide and install if needed additional RTU cards for metering and telemetry as required by the latest Xcel Energy Interconnection Guidelines. The direct cost will be charged to the Interconnection Customer.

1.13. **Communications:** To meet its Communications obligations, the Interconnection Customer shall be responsible for making arrangements with the local phone company to provide telephone circuits as required by the Transmission Owner. Transmission Owner equipment may include, but is not limited to, the following: relay communication equipment, RTU, and disturbance monitoring equipment at the new Switching Station. Prior to any construction, the Interconnection Customer is required to contact the Transmission Owner substation-engineering department for all communication details.

The following communications schematic diagram, which includes communication equipment information for the Interconnection Customer, Transmission Provider (Southwest Power Pool) and Transmission Owner (Southwestern Public Service), is provided to assist the Parties.

A schematic outlining the proposed communications is provided below:

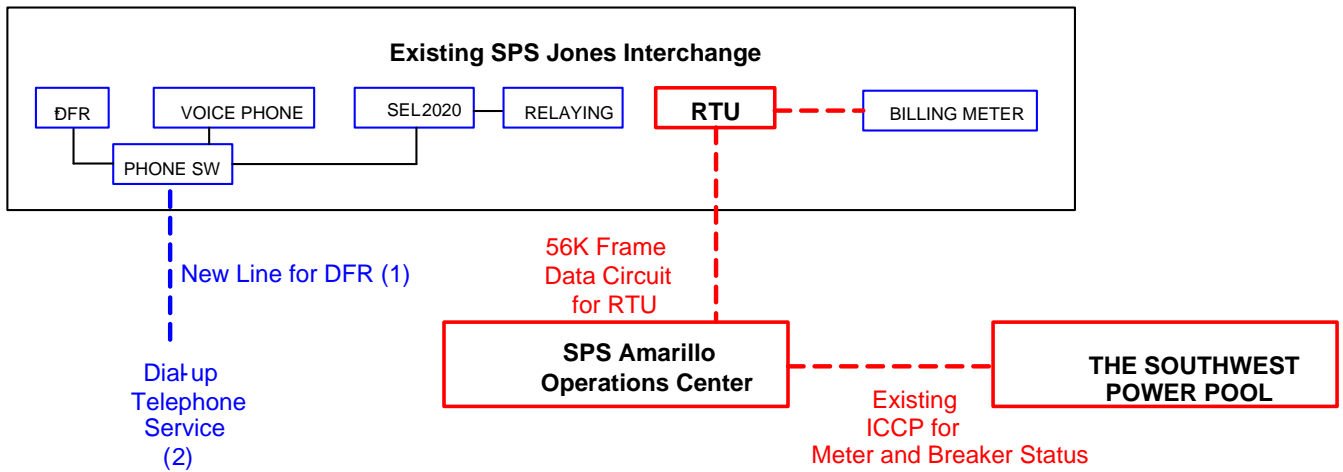

The Interconnection Customer shall be responsible for providing fiber optic communication circuit installed in their overhead transmission line static wire for protective relaying from the customer substation to the existing Jones Interchange indicated in Section 1.9.

2. Transmission Work:

- 2.1. The Interconnection Customer will construct, own, operate, and maintain any customer owned 230 kV transmission line from the Interconnection Customer's substation to the Interconnection Point at SPS Jones Interchange. This line is shown in Appendix A, Figure A-1 and is estimated to be 200 feet or less. **The SPS transmission design group prior to any construction by the Interconnection Customer or its contractor on any customer 230 kV transmission lines, or doing work in close proximity to any SPS transmission line, will require an engineering review of the customer's design. It is the Interconnection Customer's responsibility to initiate the design review in a timely manner before construction of any transmission line begins. If the review has not been made or the design at any of the aforementioned locations is deemed inadequate, the crossing(s) and or termination into the interchange will be delayed until the matters are resolved. SPS will not be held responsible for these delays.**

3. Right-Of-Way:

- 3.1. **Permitting:** Permitting for the construction of a new 230 kV line terminal at Jones Interchange is not required from the Public Utility Commission in the State of Texas. The interconnection customer will be responsible for any permitting and right of way of their substation and the 230 kV transmission line from their substation to the Interconnection Point at Jones Interchange.

4. **Construction Power and Distribution Service:** It is the sole responsibility of the Interconnection Customer to make arrangements for both construction and station power, which may be required for the Interconnection Customer's generation facility. **Additionally, if the Interconnection Customer's substation(s) and/or construction site(s) are located outside of the SPS service area, SPS cannot provide station power (retail distribution service) and the Interconnection Customer needs to make arrangements for distribution service from the local retail provider.**

5. Project and Operating Concerns:

- 5.1. Close work between the Transmission group, the Interconnection Customer's personnel and local operating groups will be imperative in order to meet any in-service date that has been established
- 5.2. The Interconnection customer will be required to maintain a Power Factor of 0.95 lagging and a 0.95 leading at the Point of Interconnection (POI). This is required to maintain acceptable dynamic voltage rise as per latest revision of the Xcel Energy Interconnection Guidelines for Transmission Interconnection Producer-Owned Generation Greater than 20 MW, is available at:
(http://www.xcelenergy.com/Texas/Company/Transmission/Pages/Transmission_Services_Interconnection_Guidelines.aspx).

6. **Fault Current Study:** The available fault current at the interconnection location, without and with any contribution from the new generator facilities, is shown in Table 2.

Table 2, - Available fault current at interconnection location

Short Circuit Information without contribution from new Generator Facilities (GEN 2011-045)				
Fault Location	Fault Current (Amps)		Impedance (Ω)	
	Line-to-Ground	3-Phase	Z^+	Z^0
230 kV Bus	14,814	12,366	$0.8358 + j10.7057$	$0.294 + j5.406$

Short Circuit Information with contribution from new Generator Facilities (GEN 2011-045)				
Fault Location	Fault Current (Amps)		Impedance (Ω)	
	Line-to-Ground	3-Phase	Z^+	Z^0
230 kV Bus	17,202	14,286	$0.6444 + j9.2728$	$0.223 + j4.567$

Estimated Construction Costs

The projects required for the interconnection of 180 MW Gas Generator facilities consist of the projects summarized in the table below.

Table 3, Required Interconnection Projects^c

Project	Description	Estimated Cost
	Transmission Owner Network Upgrades	
1	Disturbance Monitoring Device	\$ 0
2	Transmission Line Work	\$ 0
3	Right-Of-Way	\$ 0
4	230 kV Breaker Line Terminals	\$ 1,902,510
5	Remote Terminal Unit (RTU) and DFR	\$ 54,500
	Subtotal:	\$ 1,957,010
	Transmission Owner Interconnection Facilities (at the Interconnection Customer's expense)	
6	Communications ^d	\$ See footnote
7	Revenue metering	\$ 200,000
8	230 kV Line arrestors	\$ 30,000
	Subtotal:	\$ 230,000
	Total Cost	\$ 2,187,010

The current estimated allocation to the Jones Unit #4 project as calculated by SPP in DISIS-2011-002 using estimated costs for Jones – Lubbock South line traps; Jones – TUCO 230 kV line traps; Lubbock South – Lubbock East 115 kV line reconductor; and a 2nd 230/115 kV autotransformer at Lubbock South. The allocation cost of these network upgrades may change as the content of the GI Cluster group changes. No schedule is provided for the projects noted as network upgrades for the interconnection.

Engineering and Construction:

An engineering and construction schedule for this project is estimated at approximately 12 months. Other factors associated with clearances, equipment delays and work schedules could cause additional delays. This is applicable after all required agreements are signed and internal approvals are granted.

All additional cost for work not identified in this study is the sole responsibility of the Interconnection Customer unless other arrangements are made.

^c The cost estimates are 2012 dollars with an accuracy level of ±20%.

^d It is the Requester's responsibility to provide both the data circuit and both dial-up telephone circuits, see Section 1.13.

Appendix A

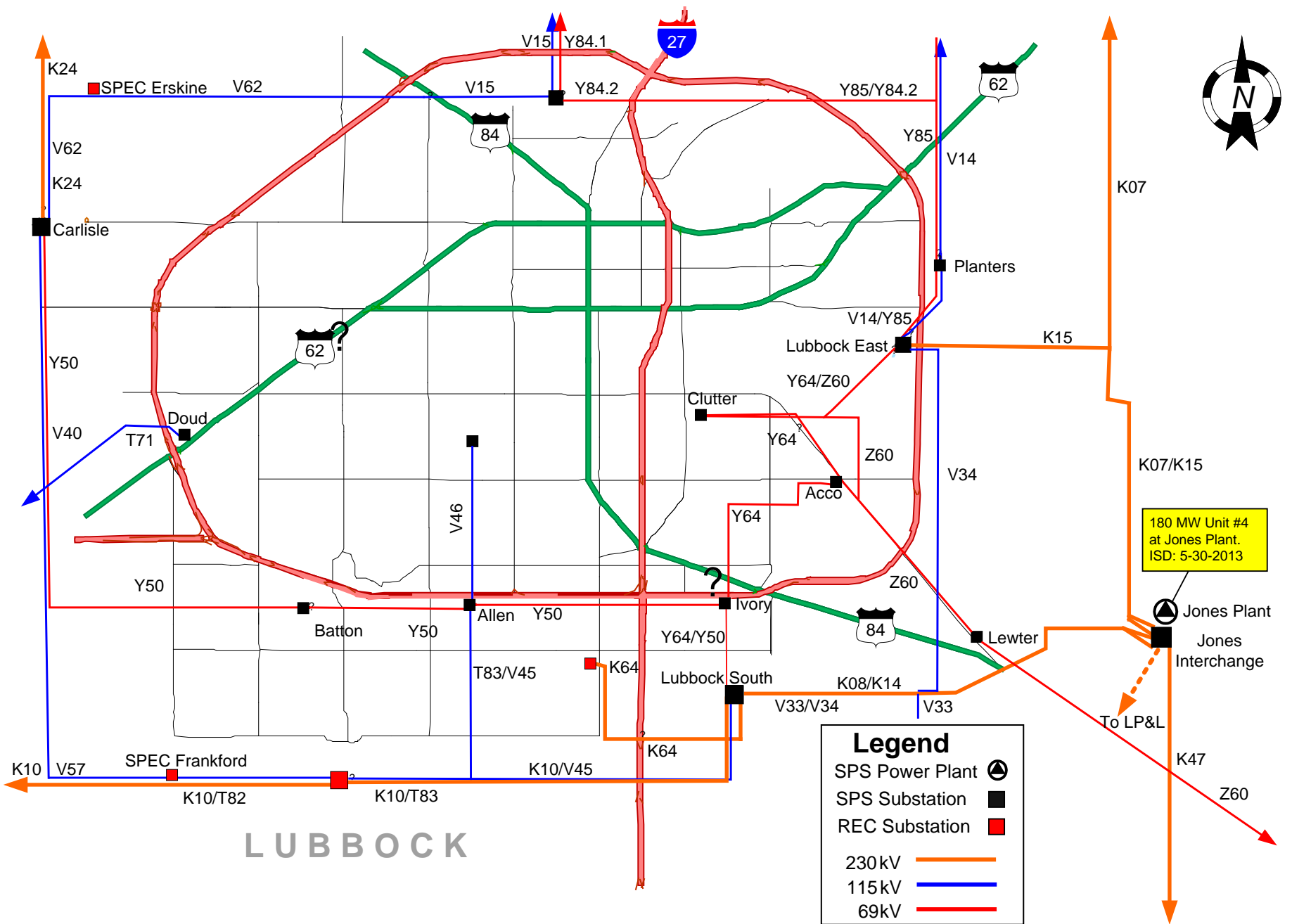

Figure A- 1 Approximate location of Jones Interchange

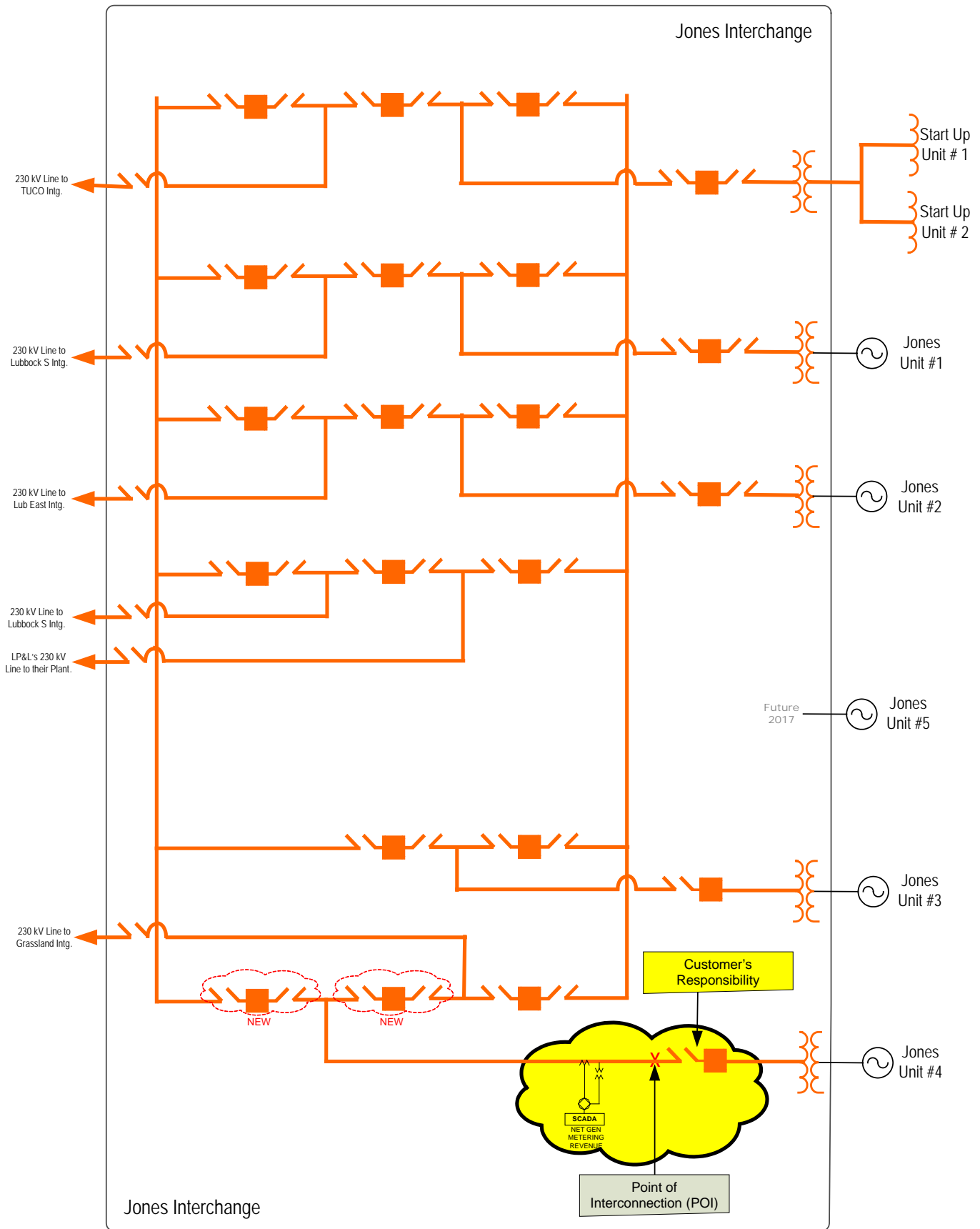

Figure A- 2 One-line Diagram of New Switching Station

Figure A- 3 Point of Interconnection & Change of Ownership (Typical)

– END OF REPORT –